

Basic structure

- Basic frame featuring aluminium profile design, completely covered.
- Height-adjustable positioning feet.
- Raising protective hood monitored by safety switches.
- Inlet and outlet tunnel as access guard.
- Switching cabinets and operating elements integrated completely in the frame.

Mechanical structure

- Cutting blade block with pneumatic blade clamping and tensioning. Designed as a quick-change system.
- Cutting movement via alternating current gear motor and eccentric lever. Adjustable cutting speed. Cycle time: Approx.: 2 – 4 seconds.
- Profile fastening via pneumatic clamping units attached on both sides of the blade block.
- Stainless steel table cover with lateral profile guides.
- Adjustable blade heating.
- Travelling feed via pulling pneumatic cylinder.
- Prepared for use of negative forms.

Electrical technology

- Operating panel with the following functions:
 - Input for production and short cut lengths.
 - Setting for cutting blade temperature.
- Interfaces:
 - Line emergency stop (on clamps).
 - "Cut end" prepared output signal (on clamps).
 - Line speed input signal.

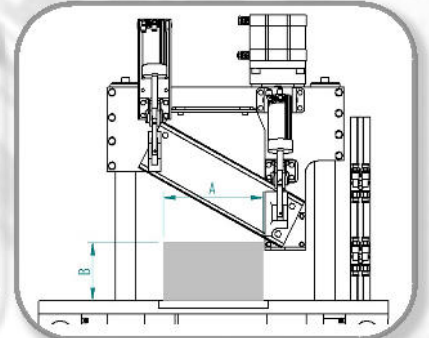

Technical data:

	PT1-200	PT1-300	PT1-350
Cutting width (A)	200 mm	300 mm	350 mm
Cutting height (B)	100 mm	120 mm	120 mm
Material speed		10 m/min	
Lengthwise travel		600 mm	
Machine width	800 mm	900 mm	1000 mm
Machine length/height	1450-2650 / 1800 mm (without inlet/outlet tunnel)		

Options/additional equipment:

The following is a selection of different options/additional equipment for this machine:

Drive via servo motor and ball screw drive

If the length precision needs to be improved (to +/- 0.5 mm per length) or if the line speed is above 10 m/min, then a machine with electrical-mechanical feed via servo motor and ball screw drive must be used instead of the standard pneumatic version.

Note: In case of higher line speeds, the entire machine must be designed to be longer in order to provide sufficient travel.

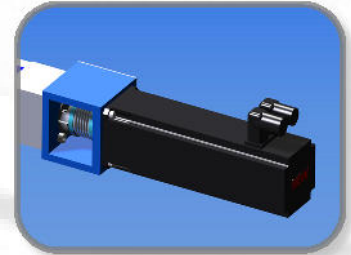

Measuring wheel housing

Upon request, a measuring wheel housing may be built directly onto the inlet of the profile guillotine. This acts as an enclosure for a measuring wheel device for recording the extrusion speed and the length of the traversing profile. Diverse measuring wheel devices are available.

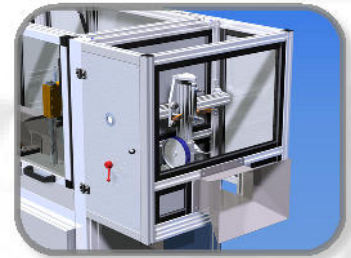

Profile supports (negative forms)

The table top of the cutting unit is equipped with mounting holes for profile support forms. The hole pattern of these mounting holes may naturally be adjusted to match the customer's hole pattern and existing support forms. Negative forms for profiles may be produced by STEIN upon request.

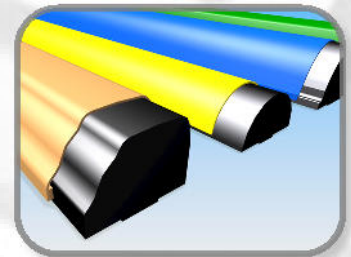

Machine height adjustment

The standard version of the machine is delivered including regular foot pads and adjusting screws for levelling at the set-up location. Optionally, height adjustment units may be built onto the inlet and outlet sides. Adjustment is possible manually using a hand-wheel/ crank or a motor.

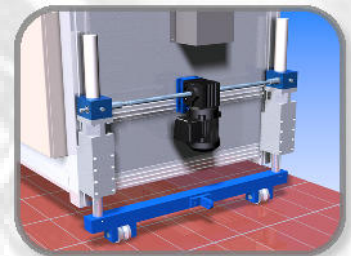

Machine able to be moved completely

The individual machines are partially placed on rail systems in profile extrusion plants in order to make movement of machines inside a line easier. Upon request, our machines may be equipped with corresponding rail wheels and clamping devices for fastening. Machines may also be practically removed from the extrusion line and integrated in another line, for example. Corresponding running wheels may be built onto the machine for this purpose.

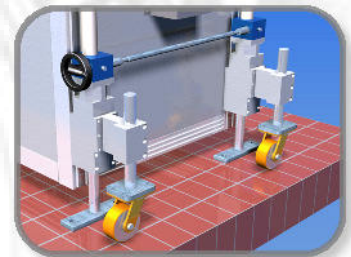

Combination option for other STEIN machines

The STEIN profile guillotine may be combined directly with a STEIN caterpillar haul-off unit or a STEIN profile foilation unit, among other items. In this case, the frames of the machines are connected directly with each other. The advantage in this case is that this reduces the overall length of the extrusion line.

